

## COMMERCIAL DUTY

# ENGINE-DRIVEN PORTABLE TRASH PUMPS

### Cast Aluminum Self-Priming Engine-Driven Pumps

- **Cast Aluminum with Cast Iron Wearparts**
- **Available with Honda, B&S Gasoline, or Hatz Diesel Engines**
- **Removable Suction and Discharge Port Sizes: 2" and 3"**
- **Max. Flow: 200 to 300 GPM**
- **Max. Head: 105 to 115 ft.**
- **Max. Lift: 26 ft.**
- **Max. Solids-Handling: 2S5- 1"; 3S5- 1.25"**
- **Silicon Carbide/Viton® Mechanical Seal**
- **Easy Clean Out with One Tool Serviceability**
- **EPDM O-Rings Standard; Optional Viton®\***
- **Optional Wheel Kit**



**Model 3S5XHR**



**Model 2S5XHR**

High-volume, self-priming centrifugal trash pumps come standard with a ductile iron impeller to resist abrasion and one tool serviceability for cleanout. All pumps feature aluminum housing, cast iron wearparts, built-in check valve, suction strainer and heavy duty steel frame. Standard Flanges with male NPT threads.

Many IPT Trash Pumps are readily available "Off-the-Shelf" for fast 24 hour shipment. For use with non-flammable liquids which are compatible with pump component materials.

Viton® and Teflon® are registered trademarks of E.I. DuPont.

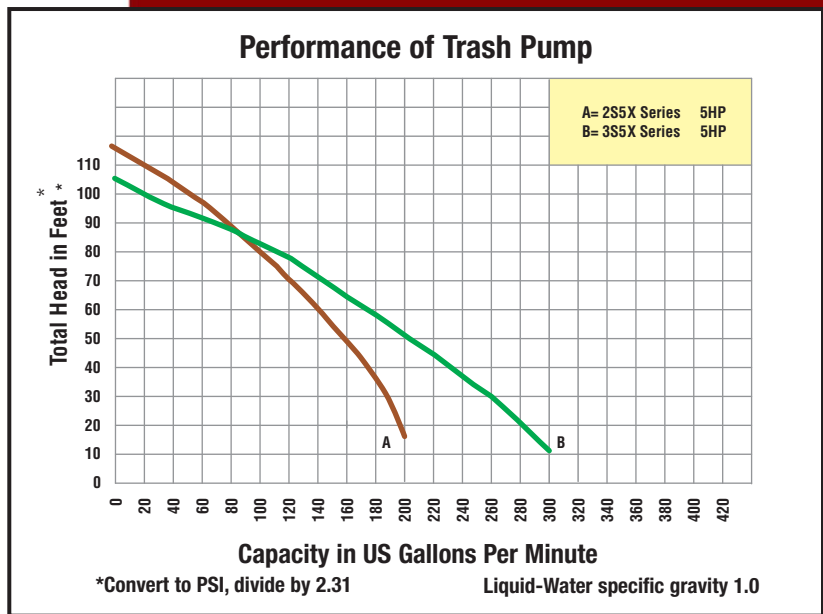

# PORTABLE TRASH PUMPS

## 2" TRASH PUMPS (EPDM O-RINGS AND CHECK VALVE)

ALUM. MODEL NO.	SHIP WT.	CURVE	PORTS	DRIVER	SEAL	RUN TIME	TANK SIZE
2S5XAR	87 lbs.	A	2" NPT	B&S CP650	Viton <sup>®</sup> /Sic-Sic	100 min.	3 qt.
2S5XHR	91 lbs.	A	2" NPT	Honda GX160	Viton <sup>®</sup> /Sic-Sic	100 min.	3.8 qt.
2S5XZR	112 lbs.	A	2" NPT	Hatz Diesel 1B20	Viton <sup>®</sup> /Sic-Sic	110 min.	3.1 qt.

Maximum Solids-Handling Capability: 1" Diameter

## 3" TRASH PUMPS (EPDM O-RINGS AND CHECK VALVE)

ALUM. MODEL NO.	SHIP WT.	CURVE	PORTS	DRIVER	SEAL	RUN TIME	TANK SIZE
3S5XAR	96 lbs.	B	3" NPT	B&S CP650	Viton <sup>®</sup> /Sic-Sic	100 min.	3 qt.
3S5XHR	100 lbs.	B	3" NPT	Honda GX160	Viton <sup>®</sup> /Sic-Sic	100 min.	3.8 qt.
3S5XZR	121 lbs.	B	3" NPT	Hatz Diesel 1B20	Viton <sup>®</sup> /Sic-Sic	110 min.	3.1 qt.

Maximum Solids-Handling Capability: 1.25" Diameter

## 5/8 THREADED KIT (SINGLE)

ALUM. MODEL NO.	ALUM. SHIP WT.	SEAL TYPE & ELASTOMER/FACES	MOUNTING
2S5X	40 lbs.	Viton <sup>®</sup> /Sic-Sic	Handle
3S5X	46 lbs.	Viton <sup>®</sup> /Sic-Sic	Handle

### Standard Features:

- Cast Iron Impeller
- One Tool Serviceability, Tool Included with Engine-Driven Models
- Silicon Carbide, Self-Lubricated Seal with Graphite Impregnated Seat and EPDM Elastomers
- Heavy Duty Steel Frame
- Large Pump Casing
- Built-In EPDM Check Valve
- Removable/Replaceable Cast Iron Suction/Discharge Ports
- Discharge Port Rotates in 90° Increments
- Choice of Honda and Briggs & Stratton Gas or Hatz Diesel Engines
- Optional Wheel Kit Available
- Strainer Included
- Rubber Foot Mounting
- Maximum Temperature 180° F
- Optional Viton<sup>®</sup> O-Ring / Check Valve Available
- Pedestal Version Available

**WARNING: Do not use in explosive atmosphere or for pumping volatile flammable liquids.**

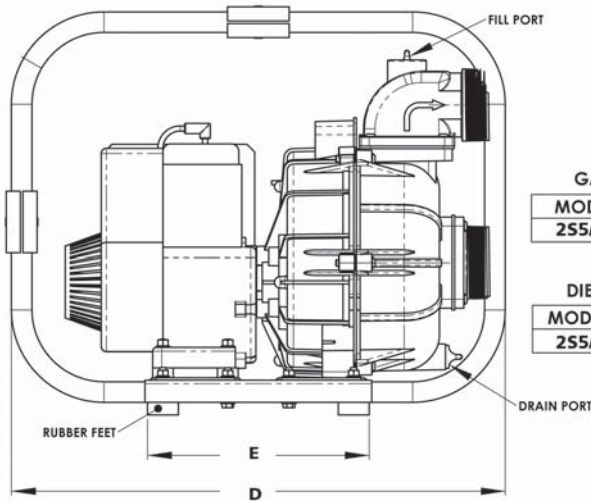

GAS ENGINE DRIVEN PUMPS	
MODEL - GAS	"H"
2S5/3S5X?R	7.4 [188]
DIESEL ENGINE DRIVEN PUMPS	
MODEL - DIESEL	"H"
2S5/3S5X?R	7.9 [200]

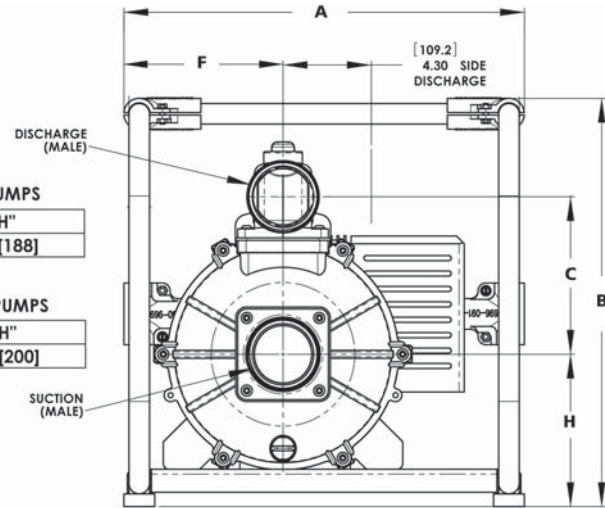

**DIMENSIONS:**  
INCHES

(MILLIMETERS)

MODEL	A	B	C	D	E	F	Dis.*	Suc.*
2S5X	18.75	18	7.7	24	10.8	7.5	2.00	2.00
	(476)	(457)	(195)	(610)	(274)	(190)		
3S5X	18.75	18	7.7	24	10.8	7.5	3.00	3.00
	(476)	(457)	(195)	(610)	(274)	(190)		

(\*) STANDARD NPT (MALE) PIPE THREAD.



See price book page 4

The Gorman-Rupp Company reserves the right to discontinue any model or change specifications at any time without incurring any obligation. Viton<sup>®</sup> and Teflon<sup>®</sup> are registered trademarks of E.I. DuPont.

CP13-14 / 1208