

A Simple, Cheap, Clean, Reliable, Linear, Sensitive, Low-Drift Transducer for Surface Pressure

Eric Perez*

Laboratoire de Physique Statistique, de l'Ecole Normale Supérieure, associé aux universités Paris 6 et Paris 7, 24 Rue Lhomond, 75231 Paris Cedex 05, France

Joe Wolfe

Biophysics Department, School of Physics, University of New South Wales, P.O. Box 1, Kensington 2033, Australia

Received July 21, 1993. In Final Form: January 3, 1994

The reduction of the surface tension of a liquid by a monolayer of surfactant is called the surface pressure of the monolayer. The accurate control and measurement of surface pressure are required for the study of monolayer properties and for the deposition of Langmuir-Blodgett films on solid surfaces.¹

We report here the design of a transducer⁴ for measuring the surface pressure of insoluble monolayers at the liquid-air interface in a Langmuir film balance. It is simple, cheap, clean, reliable, linear, and sensitive, has low drift, operates in null mode, and makes little disturbance of the interface. The sensitivity is as good as those of sensitive devices previously reported.² Moreover, its design provides several additional advantages that are usually incompatible: high linearity, large dynamic range, low drift, and low cost and ease of construction.

The design uses a floating barrier; in that respect it is like the original method of Langmuir³ and like several commercially available systems. Floating barriers are widely used for the study of insoluble monolayers. The novelty is the use of an optical lever and null mode. These features give the device high linearity, high sensitivity, and low drift. No changes of the instrument setting are required for measurements over the whole range of surface pressures that are encountered in monolayer studies, and high sensitivity is achieved over the entire range. The simplicity of the design makes it clean, reliable, and cheap. It can be quickly constructed from a Teflon sheet and readily available electronic components.

We use a floating Teflon boom whose width is a large fraction of that of the Langmuir trough to obtain maximum sensitivity. It is fused to Teflon ribbons attached to supports on either side of the trough (see Figure 1). It is permanently in place and so requires no separate preparation apart from cleaning. When the trough is empty, it stands on legs on the bottom of the trough.

At one end the boom is located by a fixed stainless steel needle. Symmetrically at the other end, it is located by a needle which is rotated about a vertical axis by a galvanometer coil. The coil, magnet, supporting bearings, and return springs were removed from a sturdy old ammeter such as may be found in the junk stores of most physics departments. The torque at full deflection and the length of the boom determine the length of the lever arm required for the moving needle. On the axis of the coil is fixed a mirror which reflects a collimated beam of light from a fixed bulb onto a pair of photoresistors. The

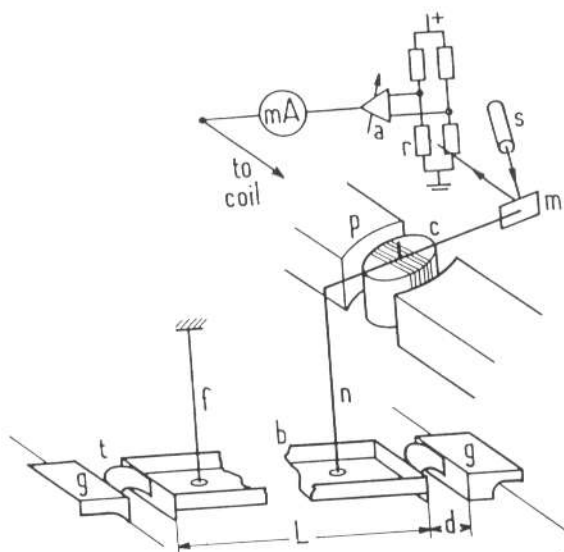

Figure 1. Schematic diagram of the transducer: (a) amplifier; (b) boom; (c) coil; (f) fixed stainless steel needle; (m) mirror; (n) moving stainless steel needle; (p) poles of magnet; (r) photoresistors; (s) collimated light source; (t) Teflon tape; (g) Teflon blocks clamped on each side of the trough. This schematic diagram shows most of the features, but is not to scale. The coil bearings and the return springs of the galvanometer have been omitted for clarity. g, t, and b partition the liquid surface hermetically into two parts.

relative orientations are such that, with the barrier in its central, reference position, the currents in the two photoresistors are equal. The difference between potential differences across the two photoresistors is used as the out-of-balance signal in a feedback loop: it is amplified with large gain and input to the galvanometer coil that moves the boom. This feedback loop maintains the boom at or extremely close to the reference position. In the original design, the feedback loop was analogue and its performance was satisfactory. In the present fully automated version we use digital feedback. The sensitivity of measurement is to some extent a function of the time over which the measurement is made (integration time) and the gain of the feedback loop and its sensitivity to the position of the needle.

The current supplied to the galvanometer coil is proportional to the force produced at the rotating needle, and this is calibrated using known weights and a lever which produces a horizontal force. The proportionality of magnetic force and current, together with the use of null displacement, makes the system highly linear. In mechanical equilibrium at the reference position, the force supplied by each of the needles is $(1/2) \Pi(L + d)$, where Π is the surface pressure difference acting on the boom, L is the length of the boom, and d is the distance between the end of the boom and the fixed support. Mechanical asymmetries in the Teflon ribbon are neglected to obtain the above equation. Constant offsets due to such asymmetries are of no consequence because the zero of surface pressure is calculated at a clean interface. Variations in such asymmetries are small. Teflon with a thickness of $13 \mu\text{m}$ was used for the ribbon to minimize its stiffness and thus the mechanical effects of asymmetries.

When Langmuir-Blodgett films of insoluble surfactants are deposited, the surface pressure is maintained constant while surfactants are transferred from the air-water interface to the surface of a solid object passed through

(1) Gaines, G. L. *Insoluble monolayers at liquid-gas interfaces*; Interscience Publishers: New York, 1966.
 (2) Albrecht, O.; Sackmann, E. A precision Langmuir film balance measuring system. *J. Phys. E: Sci. Instrum.* 1980, 13, 512-515.
 (3) Langmuir, I. The constitution and fundamental properties of solids and liquids. II. Liquids *J. Am. Chem. Soc.* 1937, 39, 1848-1906.
 (4) Plans and circuit diagrams are available upon request from E.P.

it. A sweeper across the trough (a two-dimensional piston) is moved to vary the area occupied by the monolayer. Movement of the sweeper can thus regulate the surface pressure. For the mode in which lateral pressure is constant, we maintain constant current in the coil and use a different feedback system to displace the sweeper in response to the out-of-balance signal. The sweeper is moved by a screw: its motion is thus considerably slower than that of the measuring boom. The sweeper also has some mechanical hysteresis. The measuring boom is capable of rapid motion without measurable hysteresis, although its displacement is small. The rapid transient response of the boom avoids oscillation by the sweeper and minimizes vibration in the system.

We use a sweeper whose lower edge is below the surface of the liquid in the trough. The bottom edges of the transducer boom and the Teflon ribbons are also below the surface so there is no problem with leaks.

The zero is determined by making a measurement on a surface without a monolayer. The magnitude of the error induced by variations in the offset and other drifts can be estimated by making repeated measurements on such a surface. These are on the order of $10 \mu\text{N}\cdot\text{m}^{-1}$. Calibration is performed using known forces applied to the barrier using a lever and weights. Calibration is accurate to about 0.3% and the measurement of $L + d$ to about 0.4%, so we obtain measurements of Π with a precision of $\pm 0.5\%$. Over most of the range of surface pressure, the sensitivity is much better than the precision. The sensitivity can be measured using known, constant forces. An example is displayed in Figure 2 which shows a small part of a compression isotherm of dioctadecyldimethylammonium bromide (DODAB) in the low-pressure region. At zero pressure, where the sensitivity is poorest, the standard deviation is $11 \mu\text{N}\cdot\text{m}^{-1}$ in a series of repeated measurements made with an integration time of 20 s. The drift shown in Figure 2 is about $2 \mu\text{N}\cdot\text{m}^{-1}$ in 10 min. This data set however was obtained under optimal conditions in that sufficient time was left for the monolayer and the contact angle of water on Teflon to equilibrate. Typical values of drift under normal operating conditions are less than $7 \mu\text{N}\cdot\text{m}^{-1}$ per minute. With respect to the full-scale range, the latter value may be expressed as $1.7 \times 10^{-6} \text{ s}^{-1}$.

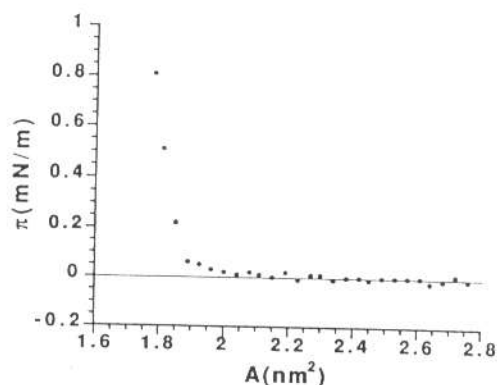

Figure 2. Compression isotherm of DODAB in the low-pressure region. At zero pressure, the standard deviation in repeated measurements is $11 \mu\text{N}\cdot\text{m}^{-1}$.

The surface pressure can be measured over the range from 0 to $70 \text{ mN}\cdot\text{m}^{-1}$ without changing any of the instrument settings that affect sensitivity (including integration time, feedback gain, and feedback sensitivity). At higher pressures ($35 \text{ mN}\cdot\text{m}^{-1}$), the same instrument settings give a standard deviation of $3.3 \mu\text{N}\cdot\text{m}^{-1}$. With an integration time of 1 s, the standard deviation is $23 \mu\text{N}\cdot\text{m}^{-1}$ at zero pressure and $9 \mu\text{N}\cdot\text{m}^{-1}$ at higher pressures ($35 \text{ mN}\cdot\text{m}^{-1}$). The dynamic range is thus between 3000 and greater than 6000, depending on the integration time.

Similar sensitivity and precision are available with other designs.² The main advantages of the design reported here are those of the null mode measurement and the simplicity of construction. These features of the device give it a large dynamic range and make it inherently linear and inherently reliable.

The prototype device has been in use for an average of several hours a day over the last five years, and no maintenance has been required. Only Teflon and the two points of stainless steel touch the liquid, so cleaning is simple. The rapid feedback response and lack of vibration allow the deposition of highly homogeneous Langmuir-Blodgett films. The lack of leaks and low drift allow the accurate measurement of isotherms for insoluble monolayers including reliable, long-term measurements under automated control.