

# Mechanical Properties of the Plasma Membrane of Isolated Plant Protoplasts<sup>1</sup>

## MECHANISM OF HYPEROSMOTIC AND EXTRACELLULAR FREEZING INJURY

Received for publication March 31, 1982 and in revised form October 7, 1982

JOE WOLFE<sup>2</sup> AND PETER L. STEPONKUS

Department of Agronomy, Cornell University, Ithaca, New York 14853

### ABSTRACT

The volume of isolated protoplasts of rye (*Secale cereale* L. cv Puma) in a suspending solution at constant concentration is shown to be negligibly changed by tensions in the plasma membrane which approach that tension necessary to lyse them. This allows a detailed investigation of the plasma membrane stress-strain relation by micropipette aspiration.

Over periods less than a second, the membrane behaves as an elastic two-dimensional fluid with an area modulus of elasticity of 230 millinewtons per meter. Over longer periods, the stress-strain relation approaches a surface energy law—the resting tension is independent of area and has a value of the order 100 micronewtons per meter. Over longer periods the untensioned area, which is defined as the area that would be occupied by the molecules in the membrane at any given time if the tension were zero, increases with time under large imposed tensions and decreases under sufficiently small tension. It is proposed that these long term responses are the result of exchange of material between the plane of the membrane and a reservoir of membrane material. The irreversibility of large contractions in area is demonstrated directly, and the behavior of protoplasts during osmotically induced cycles of contraction and expansion is explained in terms of the membrane stress-strain relation.

those of other membranes hitherto studied, and that particular mechanical properties may, in part, confer on a given protoplast its propensity to lyse during a given freeze-thaw cycle, or other cycle of osmotic contraction and expansion.

Previous experimental and theoretical studies of the mechanical properties of biological membranes have been almost exclusively of sea urchin eggs (4, 15) and RBC<sup>3</sup> (16, 19, 24) and have usually considered only small or zero changes in area. The mechanical properties of RBC have been considered in several sophisticated analyses (3, 5) and the classical treatment of viscoelasticity has been extended to describe the SSR of RBC (6). Tensions have been measured in the membranes of protoplasts from giant algal cells (12) but, as in Reference 15, changes in area were not reported.

Previously (28), we have reported briefly the measurement of the SSR of the plasma membrane of isolated rye protoplasts, using the elastimeter of Mitchison and Swann (15). In this paper we report: (a) an analysis of the use of the elastimeter which demonstrates that, in this system, changes in area may be determined more accurately than in other systems hitherto studied; (b) measurements of the SSR of the protoplast plasma membrane including its resting tension, its elastic modulus, the time dependence of area changes caused by imposed constant tensions, and the change with time of the tension necessary to maintain a given deformation in area; and (c) a direct demonstration of the critical role of membrane contraction in lysis caused by osmotically induced contraction and expansion.

### MATERIALS AND METHODS

Seedlings of rye (*Secale cereale* L. cv Puma) were grown as previously described (25) for 2 weeks at 20/15°C (day/night, 13-h photoperiod). Under these conditions, the seedlings did not cold acclimate and 50% of the crowns survived a freeze-thaw cycle to -2°C. Protoplasts were enzymically isolated in 0.53 Osm sorbitol solutions (in which their average size is inferred to be approximately equal to that *in vivo*) using a method previously described (25), except that the leaves were brushed with carborundum powder instead of being finely chopped prior to digestion. Protoplasts ranged in radius from 7 to 25 μm in the 0.53 Osm suspending media. Except as noted, those with radii of 20 ± 1 μm were routinely chosen for the experiments reported here.

The elastimeter of Mitchison and Swann (15) comprises a micropipette which abuts the cell and a manometer with which a negative pressure is applied (Fig. 1). Pipettes were made by pulling 1-mm diameter glass tubing on a commercial electrode puller. The tips were then snapped off and only those with a neat planar

When the volume of isolated protoplasts is reduced by transferring them to a medium with greater osmotic pressure, the area of their plasma membranes is also reduced and they regain their spherical shape. Thus, osmotic expansions and contractions of spherical protoplasts both produce changes in the area of the plasma membrane.

Steponkus and co-workers (22, 23, 25) have shown that one may ascribe to a population of protoplasts an absolute surface area increment, greater expansions than which cause the plasma membrane to lyse. This increment is independent of the extent of contraction. One form of freeze-thaw injury suffered by protoplasts from nonacclimated tissue is the result of incompletely reversible contractions of the plasma membrane during freezing of the suspending medium (22, 23, 25). These studies suggest that, during large deformation, the mechanical properties of the plasma membrane of isolated protoplasts are qualitatively different from

<sup>1</sup> This material is, in part, based on work supported by the National Science Foundation under Grant PCM-8021688 and the United States Department of Energy under Contract DE-AC02-81R10917. Department of Agronomy Series Paper 1426.

<sup>2</sup> Current address: School of Physics, The University of New South Wales, P.O. Box 1, Kensington, N. S. W. 2033, Australia.

<sup>3</sup> Abbreviations: RBC, red blood cells; N, Newton; Osm, osmolal; SSR, stress-strain relation; TSAI, tolerable surface area increment.

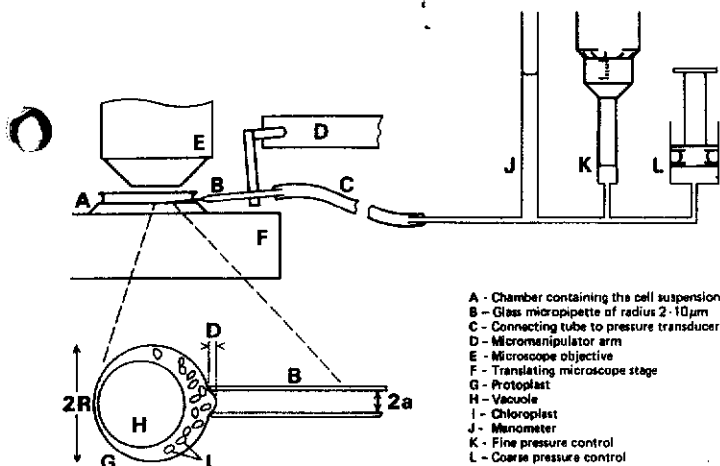

FIG. 1. The modified version of the elastimeter of Mitchison and Swann (15).

annulus to which the pipette axis was normal were retained. These pipettes were then very slightly annealed in a warm heating coil to seal any submicroscopic cracks and to allow the surface tension of the glass to blunt any sharp irregularities on a submicroscopic scale which otherwise might have impeded the movement of the membrane, but not to the extent that microscopically observable rounding of the edges occurred.

Pipettes were mounted on a micromanipulator and connected via a flexible tube to a manometer in parallel with two syringes, one of which was a micrometer syringe for fine pressure control (Fig. 1). The manometer and the pipettes were loaded with a sorbitol solution of the same concentration as the cell suspension. All solution osmolalities were determined with a freezing point osmometer. In a few experiments, one drop of homogenized milk was added to 3 ml of the cell suspension. The fat globules were just resolvable and their uniform movement was used to indicate flow in the solution. With no obstruction in the pipette, the pressure was adjusted to produce no net movement of the globules; this pressure was used to establish the manometer reading for which  $P = 0$  before and after each experiment. When a protoplast was on the pipette, movement of globules in the pipette would indicate a leak and no measurement would be taken. After some practice, it was possible to use the motion of a chloroplast from another (ruptured) protoplast to indicate any currents, and the milk was omitted.

Measurements were conducted 3 to 5 mm from the air-solution interface in a hemocytometer chamber 0.1 mm deep and with a volume of 9  $\mu\text{l}$ . Experiments were conducted within 6 min of loading the hemocytometer to ensure that any concentration gradient caused by evaporation at the air-solution interface had negligible influence in the region being used for measurements. This consideration is discussed in "Accuracy of Measurements."

Experiments to confirm the constancy of volume and the accuracy of Equation 3 used large pipettes ( $5 \mu\text{m} < a < 8 \mu\text{m}$ ) to produce large area deformations. The pressure was quickly lowered to produce a tension of  $3 \text{ mN m}^{-1}$  in the membrane and  $D$  and  $d$  were measured as the protoplast slowly intruded into the pipette. When the intrusion stopped or markedly slowed (usually due to intrusion of the vacuole), the pressure was slowly decreased until lysis occurred. The last value of  $D$  was recorded to calculate the TSAI.

For the independent manipulation of volume and area, osmotic excursions were conducted in the hemocytometer as follows: a drop of the protoplast suspension (0.53 Osm sorbitol) was injected on one side of the chamber, and a drop of hypertonic sorbitol solution (1.20 Osm) was injected on the other side. The point of a needle was used to draw a long narrow neck between the two

drops, producing a localized region of steep concentration gradient between two larger volumes of iso- and hypertonic solution. (The diameters of protoplasts at positions remote from the neck did not observably change over 5 min, indicating that, over this time, the amount of sorbitol that had diffused through the neck had changed the concentration in the two original drops by less than 4%.) Protoplasts were 'towed' with the pipette (loaded with hypertonic solution) about 5 mm through the narrow neck to the hypertonic side. After 5 min, a drop of isotonic solution was injected into the original isotonic side and the protoplast returned to isotonic with the pipette.

## RESULTS

### ANALYSIS OF THE USE OF THE ELASTIMETER

The elastimeter of Mitchison and Swann (15) comprises a micropipette which abuts a cell and to which a negative pressure is applied. The region of the membrane delimited by the pipette is distorted to produce a curvature larger than that in the rest of the membrane. From these curvatures and the pressure applied, the tension  $\gamma$ , is obtained (15) from

$$\gamma = -P/(2/r - 2/R) \quad (1)$$

where  $P$  is the pressure in the pipette,  $R$  the radius of the cell, and  $r$  the radius of the deformed section. The assumptions underlying the application of this equation to the protoplast plasma membrane are discussed in Appendix 1.

Small changes in the surface area of protoplasts (diameters 30 ~ 45  $\mu\text{m}$ ) may not be measured directly inasmuch as the limits of optical resolution of the diameter introduce an error of  $\pm 3\%$  in the total area  $A$ . We show here that, because of the osmometric properties of the protoplast and the fragility of its membrane, the volume is conserved (to an excellent approximation) during manipulations with the elastimeter. This constancy of volume allows a more accurate determination of area changes than is possible in other systems studied previously.

Consider a pressure difference across a membrane ( $P_i$ ) which is the result of osmotic concentrations which differ by  $\Delta C$ .  $P_i = (R_g T) \Delta C$  where  $T$  is the (absolute) temperature and  $R_g$  the gas constant. If  $C$  is the external osmotic concentration and  $N$  the effective number of intracellular osmotic molecules, then  $\Delta C = N/(V - b) - C$ , where  $b$  is the osmotically inactive volume. Because the volume at osmotic equilibrium,  $V_e = N/C + b$ , the amount by which the volume differs from an ideal osmometer is given by

$$\frac{V - V_e}{V - b} = -\frac{\Delta C}{C} = \frac{-P_i}{C(R_g T)} = \frac{2\gamma}{RC(R_g T)} \quad (2)$$

For  $\gamma = 1 \text{ mN m}^{-1}$ ,  $R = 20 \mu\text{m}$ ,  $C = 0.53 \text{ Osm}$ , and  $R_g T = 2.24 \times 10^6 \text{ Pa} \cdot \text{L/mol}$  (all typical values),  $\Delta C$  is  $\sim 10^{-4}$ , i.e. the volume is  $\sim 0.01\%$  smaller than calculated for an ideal osmometer. Thus, tensions of this magnitude will not sensibly change the volume of a protoplast at constant concentration.

The constancy of volume has been tested for large deformations in the pipette using tensions approaching those which lyse the membrane. The geometry of the micropipette elastimeter (Fig. 2) is analyzed in Appendix 2, and expressions for the surface area and volume of a protoplast are given in terms of the radius of the pipette ( $a$ ) and the variables  $d$  and  $D$  which are defined in Figure 2. Figure 3 plots the volume of protoplasts (with a range of sizes) as a function of  $D$ , the length of the intrusion into the pipette. These results show that, to the accuracy of optical resolution, the volume of the protoplast is conserved.

Appendix 2 also derives the following expression for the change in area ( $\Delta A$ ) caused by deformation in the pipette employing the

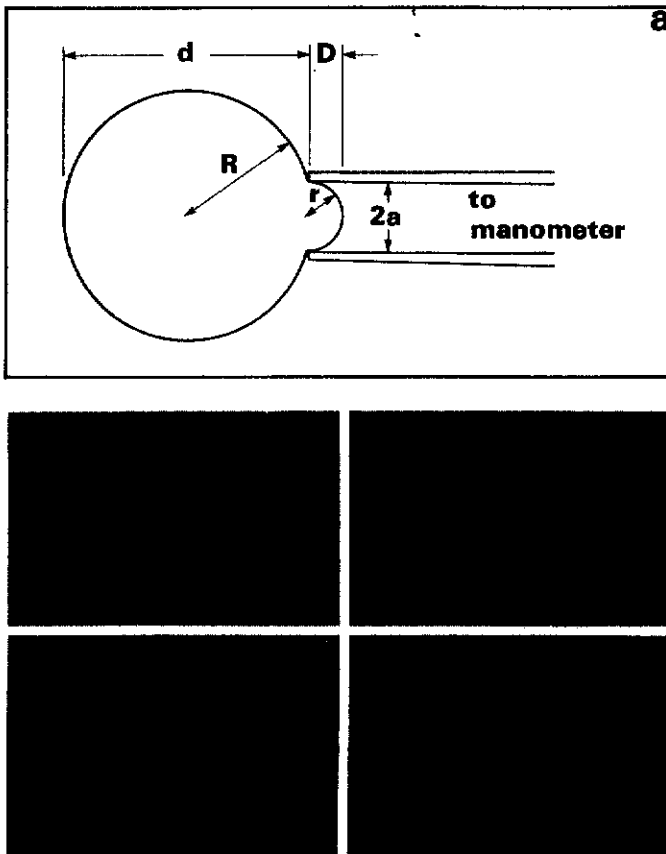

FIG. 2. a, Schematic diagram illustrating parameters determined in stress-strain measurements; b-e, Photomicrographs illustrating the  $\Delta A$  resulting from an increase in  $\gamma$ .

observation of constant volume

$$\Delta A = \begin{cases} \pi[D_0^2 + D^2 - D^3/3R - 2DD_0] & D \leq a \\ \pi[a(2D - a + 4D_0/3) + D_0^3 - 4DD_0] & D > a \end{cases} \quad (3)$$

where  $D_0 = a^2/2R$ .  $\Delta A$ , thus calculated, and the area  $A$  calculated directly from geometry, are also plotted in Figure 3 as a function of  $D$ . Equation 3 is shown to be accurate to the limit of optical resolution. In all results that follow,  $\gamma$  and  $\Delta A$  are calculated from Equations 1 and 3. All the experiments whose results are shown in Figure 3 were terminated by lysis of the plasma membrane and so the TSAI sustained before lysis is indicated on the figure. For a population of 22 protoplasts with a mean area of  $2750 \pm 200 \mu\text{m}^2$ , the mean value of TSAI thus measured was  $610 \mu\text{m}^2$  and the sample SD was  $100 \mu\text{m}^2$ . Both the mean and the variation agree well with values determined from osmotic manipulation of a protoplast population (23), but this may be fortuitous since the manner in which the tension was increased is likely to be very different from the way in which it increases during an osmotic expansion.

**Accuracy of Measurements.** The largest uncertainties introduced into measurement of the SSR are those due to the inability to resolve distances observed under the light microscope to better than  $0.5 \mu\text{m}$ . For a protoplast of radius  $20 \mu\text{m}$ , this introduces an error of  $\pm 3\%$  in the estimation of surface area ( $150 \mu\text{m}^2$  in a total area of  $5000 \mu\text{m}^2$ ). With the constant volume assumption, however, measurements of the change in area may be made with a smaller uncertainty which is determined by the accuracy to which the geometry of the deformation is known. This uncertainty is represented in Figures 3 to 6 by error bars. With a pipette of radius  $4 \mu\text{m}$  and a protoplast of radius  $20 \mu\text{m}$  (as in Fig. 4), the resultant error in  $\Delta A$  calculated from Equation 3 is  $10 \mu\text{m}^2$ .

Because the pipette constitutes a cylindrical lens and thus might be expected to cause an erroneous measurement of  $2a$  when viewed in a direction perpendicular to its axis, its diameter was measured by observation along its axis with episcopic illumination. A more precise measurement was possible after it was established (see "Results") that protoplasts conserved their volume at constant concentration. Small protoplasts were slowly drawn completely into the pipette until their shape was cylindrical with hemispherical ends. From the length of this shape, the original spherical diameter, and simple geometry, the radius of the pipette could be calculated. Since the volume of the spherical protoplast can be determined  $\pm 5\%$ , and the length of the rod-shaped protoplast can be measured  $\pm 0.5\%$ ,  $2a$  can in principle be determined as  $\pm 3\%$ . Using protoplasts of different sizes, values of  $a$  for a given pipette were calculated with a sample SD of  $0.1 \mu\text{m}$ . The cylindrical lens does not of course affect the measurement of  $D$ .

Resolution errors in  $\gamma$  are therefore not large if  $D > a$ , though they can be substantial if  $D < a$  as is indicated by the error bars in Figure 6. The pressure can easily be measured with an accuracy of  $\pm 1\%$  so it contributes only a negligible error in  $\gamma$ .

The error in  $\Delta A$  introduced by nonconservation of volume is small for changes in volume produced by hydrostatic pressures in the cytoplasm (at  $\gamma = 2 \text{ mN m}^{-1}$ , this error is about  $2 \mu\text{m}^2$ ). However, the possible effects of volume changes resulting from changes in concentration are more serious. An increase in concentration of 0.1% produces a decrease in volume of about 0.1%. For a protoplast of radius  $20 \mu\text{m}$ , this change increases  $D$  by about  $0.5 \mu\text{m}$ , i.e. introduces an error equivalent to that introduced by resolution.

Because manipulation of a fine pipette in a thin chamber becomes increasingly difficult at greater penetrations, stress-strain measurements were conducted between 3 and 5 mm from the air-solution interface. Evaporation at this interface concentrates the surface solution and solutes slowly diffuse back towards the region in which the experiment is conducted. Since concentrations will only change with time if a concentration gradient in space exists, the time dependence of concentrations will be indicated by the presence of concentration gradients. We tested for concentration gradients thus: the pipette pressure was adjusted so that the membrane was stationary in the pipette, and the pipette was then moved in the chamber (or more usually, the chamber was moved relative to the pipette). As the edge of the chamber was approached, the protoplast contracted in volume, thereby increasing its surface area to volume ratio and thus intruding farther into the pipette. If a rapid translation of the stage produces no observable change in the extent of intrusion into the pipette, the error introduced in the measured change in area by a possible change in concentration is not larger than the resolution error. If a translation of the stage by  $500 \mu\text{m}$  produced no observable change in the position of the membrane, we assumed that concentration changes were negligible. To avoid such possible errors, all stress-strain experiments were conducted within 6 min of loading the chamber.

Evaporation at the air-solution interface is also expected to change the shape of the meniscus and its surface tension, and thus affect the hydrostatic pressure in the chamber. Over 6 min, changes in hydrostatic pressure in the chamber were usually less than 5 Pa and were neglected.

#### STRESS-STRAIN RELATION

**Resting Tension.** For protoplasts whose area has not been deformed, the resting tension,  $\gamma_r$ , is typically  $100 \mu\text{N m}^{-1}$ , though the population variation is also of this order. We note that this range of resting tensions is much smaller than the tension necessary to lyse the membrane ( $\sim 4 \text{ mN m}^{-1}$ ) and is very much smaller than the area elastic modulus discussed later ( $230 \text{ mN m}^{-1}$ ). The range of values of  $\gamma_r$  is equivalent to the range of changes in

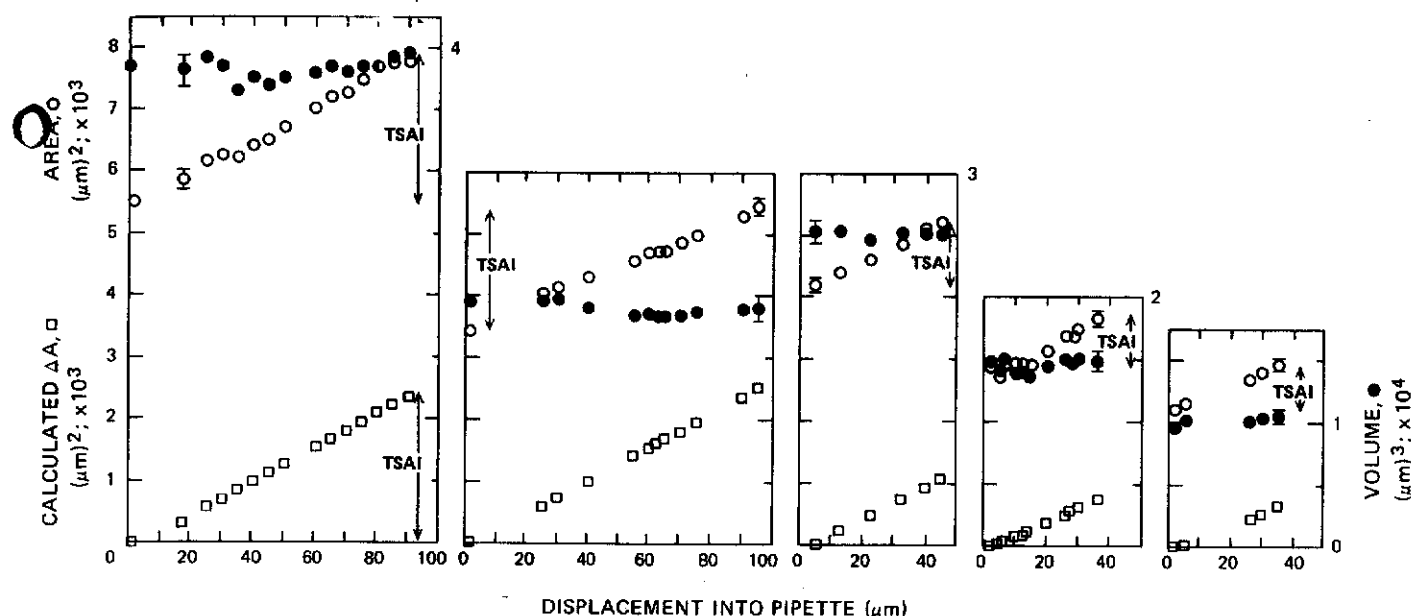

FIG. 3. The areas and volumes of protoplasts when deformed with a large micropipette. Against displacement into the pipette ( $D$ ) are plotted the area ( $\circ$ ) and volume ( $\bullet$ ) calculated from Equation 7a and the  $\Delta A$  ( $\square$ ) calculated from measurement of  $D$  and from the assumption that the protoplast behaves as an osmometer, i.e. that its volume is constant at constant concentration. The errors incurred by inability to measure distances to better than  $0.5 \mu\text{m}$  are shown in  $V$  and  $A$  on only one datum, for clarity. The errors thus introduced in  $\Delta A$  are smaller than the size of the symbols. Given the unavoidable error in calculating  $V$  and  $A$ , it is clear that they are consistent with  $V$  constant and  $\Delta A$  as calculated.

which would result from elastic expansions of the membrane of about 0.2%, so that although the relative variation is large, the absolute range of  $\gamma_r$  is small.

The same range of  $\gamma_r$  (zero to several hundred  $\mu\text{N m}^{-1}$ ) is observed for populations of protoplasts isolated in 0.53 Osm sorbitol (an osmolality that results in a cell volume inferred to be equal to that *in vivo*) and subsequently equilibrated in 0.41 or 0.70 Osmol sorbitol for 1 h or more. These osmotic manipulations produce, respectively, increases or decreases in area of 15%.

**Time Dependence of the Stress-Strain Relation.** The time-dependent SSR which is implied by the results of the aforementioned experiments may be most readily demonstrated by the response of  $\Delta A(t)$  to a step change in tension. In this series of experiments, the pipette was abutted on the protoplast and at  $t = 0$  a pressure large enough to produce a tension of  $2.00 \text{ mN m}^{-1}$  was applied over 1 s.  $D$ , and therefore  $\Delta A$ , was observed as a function of time for 3 min. The pressure was then decreased to a value only just large enough to hold the protoplast in the pipette. (This corresponded to a membrane tension of  $\approx 50 \mu\text{N m}^{-1}$ .)

The rapid increase in tension to  $2.00 \text{ mN m}^{-1}$  produced a change in area of about 1% which appeared to occur as quickly as the tension was increased, i.e. the area increased by 1% in rather less than 1 s from the time of application of the increased tension. This change was elastic: a negative area change of about the same magnitude was produced if the tension was lowered. The rapidity of this initial response indicates that, for periods of 1 s or more, the effects of the viscosity of the membrane may be neglected. Though the membrane may exhibit two-dimensional viscoelasticity in time scales much smaller than 1 s, for the periods considered here, the membrane behaves as a nonviscous two-dimensional fluid. The area continued to change with time after the increase in tension, but at a much slower rate. This area change may be considered 'plastic' in the sense that it was only very slowly reversed when the tension was relaxed. The form of this change in area with time varied for different protoplasts.

Long term (minutes) changes in area with time at constant tension were observed for a population of protoplasts. In all cases, the area increased, though sometimes with a decreased rate after

about 30 or 40 s, until the protoplast lysed, or the vacuole occluded the pipette, or the experiment was terminated at  $\leq 5$  min. The fractional rate of increase in area ( $Z = \frac{1}{A} \frac{\partial A}{\partial t}$ ) at  $\gamma = 2.0 \text{ mN}$

$\text{m}^{-1}$  was about  $10^{-4} \text{ s}^{-1}$  with a large variation in the population. Figure 4 shows a typical result. After 2 min 30 s, the tension was quickly relaxed to  $55 \mu\text{N m}^{-1}$ , and the area rapidly decreased by  $45 \mu\text{m}^2$ , and then decreased slowly with time.

Time-dependent changes in the unstretched area are also indicated by the observation of the tension required to maintain a constant area. In these experiments, a large tension was applied, rapidly producing a small intrusion into the pipette. The pressure (and thus the tension) was adjusted with time to maintain the same value of  $\Delta A$  and thus of  $A$ . Figure 5 shows a typical result. The tension decreases quickly at large tensions but the rate of decrease in tension decreases as the tension decreases. After 5 min, when the experiment ended, the tension was  $600 \mu\text{N m}^{-1}$  and still decreasing. Though the pressure may be accurately measured, a larger error is introduced by the resolution error in  $\Delta A$ . The error bars in this plot are therefore the largest change in tension which would not change  $\Delta A$  perceptibly, calculated using the elastic modulus derived from the rapid initial deformation.

**The Elastic Modulus.** From the response of  $\Delta A$  to a step change in tension (Figs. 4 and 5), it is seen that the short term (seconds) change in area is predominantly elastic or reversible. To investigate this elastic response, the membranes of protoplasts were subjected to rapid expansion-contraction sequences and a stress-strain plot ( $\gamma$  versus  $\Delta A$ ) produced. A typical result is shown in Figure 6. This plot depicts a sequence of slow expansion, rapid contraction, slow expansion, and rapid contraction (the data were taken at 20-s intervals). During a contraction, the tension is low, and Figure 4 shows that at low tensions  $\Delta A$  changes relatively slowly. Rapid contractions are therefore presumed predominantly elastic and are used to calculate the elastic modulus from  $k_A = (\delta\gamma/\delta\Delta A) \cdot A$ . The mean value was  $230 \text{ mN m}^{-1}$  and the sample SD was  $50 \text{ mN m}^{-1}$  ( $n = 28$ ). Whereas the large variation in measurements of  $\gamma_r$  principally represents the result of a large variation in  $\gamma_r$  among protoplasts, the sample SD in the measurements of  $k_A$  is

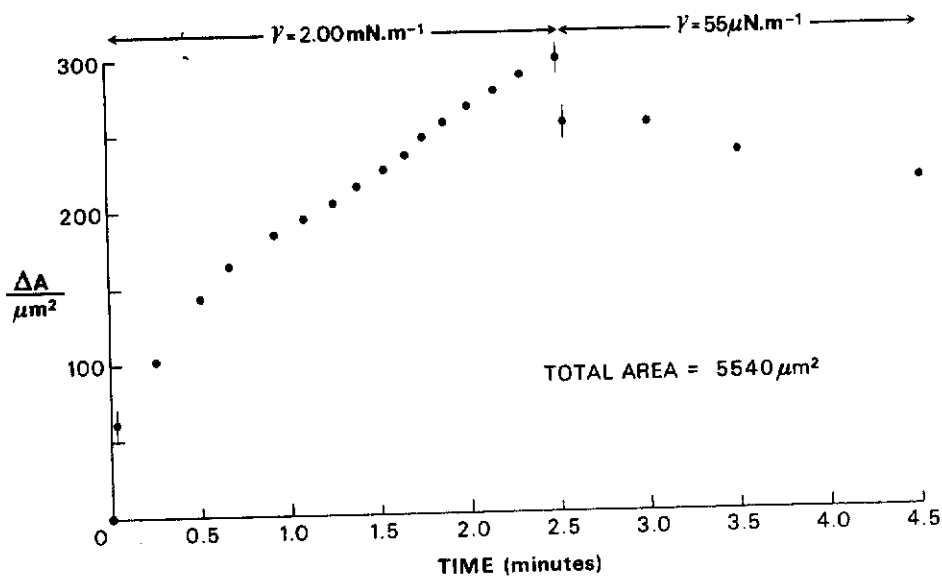

FIG. 4. This plot of  $\Delta A$  versus time at constant tension shows clearly the time dependence of the SSR. A tension  $2 \text{ mN m}^{-1}$  is applied at  $t = 0$  and an elastic deformation ( $\Delta A = 61 \mu\text{m}^2$ ) is produced virtually immediately (that is, as fast as the tension can be changed). The area continues to increase with time until, at  $t = 2 \text{ min } 30 \text{ s}$ , the tension is lowered to  $55 \mu\text{N m}^{-1}$ . This relaxation produces a rapid contraction of  $43 \mu\text{N m}^{-1}$ . Note that during the application of high  $\gamma$  there has been an extensive change in area of about  $255 \mu\text{m}^2$ . At this low tension, the area decreases with time for the remainder of the experiment.

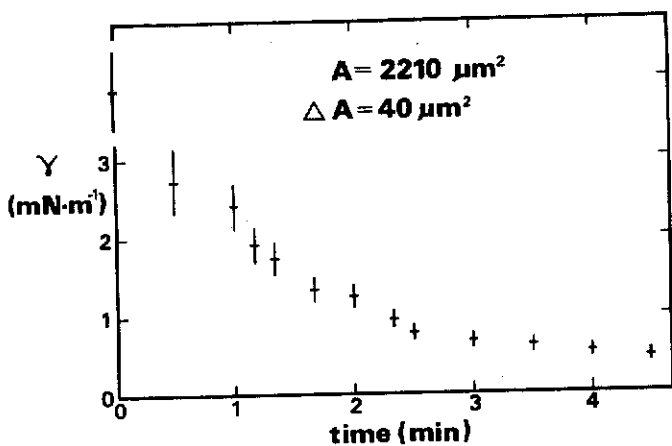

FIG. 5. To a protoplast of area  $2210 \mu\text{m}^2$  with  $\gamma_r$  about  $100 \mu\text{N m}^{-1}$  is applied a tension  $4 \text{ mN m}^{-1}$  at  $t = 0$ . This causes an immediate (elastic) area increase of  $40 \mu\text{m}^2$ . The tension is thereafter adjusted to maintain constant area. The relaxation of tension with time (as new material is incorporated) is shown.

equal to that expected due to the limitation of optical resolution, as discussed previously.

**Independent Manipulation of Volume and Area.** Previous studies (22, 23, 25) have shown that to protoplasts isolated from a given tissue may be ascribed TSAI, expansion greater than which causes lysis and which quantitatively accounts for the incidence of injury in nonacclimated protoplasts subjected to a freeze-thaw cycle (25). These conclusions were reached from studies of the behavior of populations of protoplasts. With micropipette aspiration, it was possible to test them directly.

Protoplasts of radius 19 to  $21 \mu\text{m}$  were transferred to hypertonic and returned to isotonic sorbitol solutions after 5 min. In one experiment, the protoplasts were allowed to contract in both area and volume; in another, a small tension ( $\sim 100 \mu\text{N m}^{-1}$ ) was applied with the pipette and continuously adjusted so that the area of the plasma membrane was approximately conserved, while the volume of the protoplast contracted.

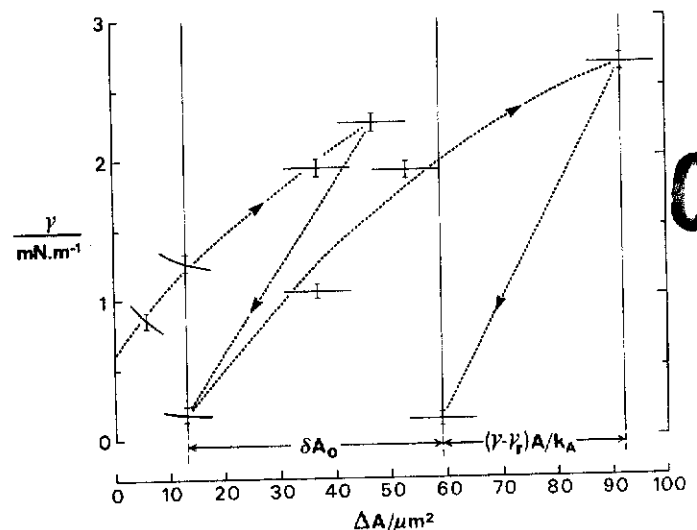

FIG. 6. A stress-strain plot ( $\gamma$  versus  $\Delta A$ ) with points taken at 20-s intervals. The protoplast has an initial total area of  $3530 \mu\text{m}^2$  and the pipette radius is  $5.2 \mu\text{m}$ . Vertical error bars represent the estimated error in the pressure. Lateral bars indicate the error introduced by an error of one-half wavelength in displacement measurements. These are not horizontal since, at small  $D$ , errors in  $D$  affect  $\gamma$  as well as  $\Delta A$ . The rapid contractions under low tension are assumed elastic, and the area change in the second expansion has therefore been divided into its elastic and extensive components, as shown.

Protoplasts allowed to contract without constraint on area contracted volumetrically over 10 to 30 s to an irregular flaccid shape. During the 5-min exposure to hypertonic conditions, the shape gradually became more regular, and in some cases returned apparently to sphericity. Of 20 protoplasts so transferred to 1.20 Osm hypertonic solution without constraint on area, 11 lysed on return to isotonic. The remaining nine protoplasts appeared to have very high membrane tensions when returned to isotonic; either their membranes were too taut to seal on the end of the pipette, or else they burst when negative pressures of a few

hundred Pa were applied.

In contrast, when area was constrained by tension to remain constant by application of a negative pressure (resulting in intrusion of the plasma membrane into the micropipette during osmotic contraction), the protoplasts always survived the return to isotonic conditions (Fig. 7). In both cases, the ratio of volume at isotonic to volume at hypertonic was in the range 1.8 to 2.0, as predicted by the Boyle-van't Hoff relation (23). All protoplasts which survived return to isotonic regained their original volume to the accuracy of optical resolution.

These experiments led to an interesting observation: the intrusion was so large ( $50 \mu\text{m} < D < 120 \mu\text{m}$ ) that the vacuole was drawn into the pipette. The long thin cylindrical section of the vacuole usually divided spontaneously into several small vacuoles (volume of the order of  $1000 \mu\text{m}^3$ ). Sometimes when this happened, the remaining vacuole would seal the pipette entrance, thereby sustaining the bulk of the pressure applied in the pipette and relaxing the tension in the plasma membrane in the intrusion. Under these conditions, the intruding portion of the protoplast tended to squeeze off protoplasmic masses, usually containing a small vacuole, into the pipette. This process of subduction could be very clearly observed in the pipette.

DISCUSSION

In a preliminary report, we have suggested that the SSR of the

plasma membrane of isolated protoplasts may be described in terms of two paradigms, an elastic law and a surface energy law (28). Over short periods of time (seconds), the amount of material in the plane of the membrane is conserved and deformations follow a simple elastic relation. Over long periods of time (minutes), the tension reverts to its resting value, independent of the induced change in area, and thus, the deformations follow a surface energy law.

In contrast, most previous analyses of membrane SSR have employed an elastic or viscoelastic law, but the membrane studied is usually that of the RBC, an atypically rigid membrane (9). (The mechanical properties of the RBC membrane are comprehensively reviewed by Evans and Skalak (6).) Since the suggestion that a membrane may obey both an elastic law and a surface energy law seems at first paradoxical, we shall discuss the manner in which these laws arise.

In a fluid mosaic membrane under no tension, the attractive and repulsive forces between membrane and water molecules are exactly balanced, and the area occupied by each molecule has that value which minimizes the free energy per molecule. If a tension stretches this membrane without changing the number of molecules in the membrane, then the area per molecule increases from that value. Because for small deformations the free energy minimum may almost always be approximated by a parabola, and because the tension is the derivative of free energy  $G$  (2.21)

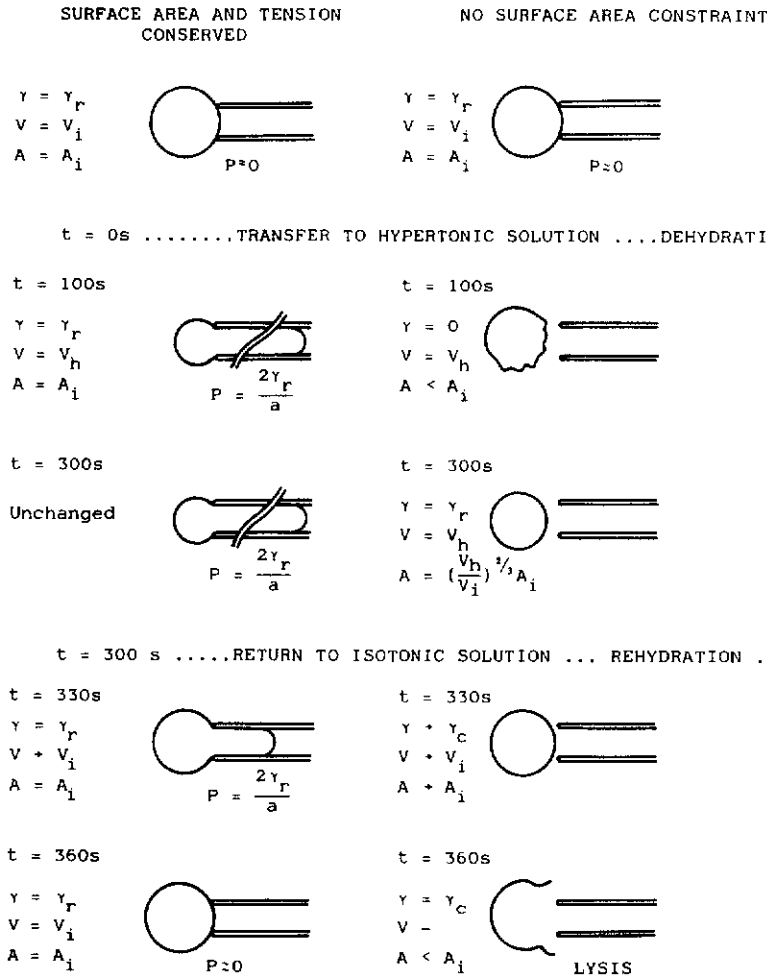

FIG. 7. The behavior of nonacclimated protoplasts during the osmotic manipulations described in the text.  $V_i$  and  $V_h$  are the volumes in the isotonic and hypertonic media and are related by the Boyle-van't Hoff law.  $A_i$  is the original area at isotonic. The arrow signifies "approaches." On the left is represented a cell whose membrane tension (and therefore area) is maintained by suitable pressure in the pipette. That on the right has no such constraint. Since the membrane of the cell never contracts, it does not lyse on (volumetric) re-expansion. The membrane on the right, however, not only contracts elastically, but also loses membrane material to the reservoir. On volumetric re-expansion, it will lyse if not all of this material may be rapidly recovered.

with respect to area, one may define an area elastic modulus by

$$k_A = A \frac{\partial^2 G}{\partial A^2} \quad (3a)$$

(see Israelachvili *et al.* (11) or Wolfe (27) for a discussion).

Suppose, however, that the number of molecules in a membrane is not conserved and that there exists a pathway whereby a reservoir may exchange material with the membrane. We define the untensioned area  $A_0$  as the area which would be occupied by the molecules in the membrane at a given time if the membrane was not subject to a tension. In this case, a stretching of the membrane raises the internal free energy, and if the addition of a new molecule can relax that energy by an amount of energy greater than that required to take it from its 'reservoir' to the membrane, then new molecules would move into the membrane, increasing  $A_0$  in order to relax  $\gamma$  (an example of Le Chatelier's principle). Further, the energy difference per unit area between the reservoir and the membrane would be the equilibrium surface free energy of the membrane (10, 27).

An elastic SSR will be time-independent if viscosity can be ignored. (In this case, the rapid initial increase in  $A$  in response to a sudden increase in tension shows that viscosity may be ignored over periods of 1 s or more.) The time dependence of the SSR for a system in which a surface energy law obtains will be determined by the rate at which material can enter or leave the membrane. In a pertinent example, when a bilayer which is contiguous with an organic solvent phase is deformed, the deformation law is an elastic law if the deformations are rapid enough (high audio frequencies [26]) but a surface energy law if the system has several seconds to equilibrate (27).

We propose that a similar situation obtains in the plasma membrane of protoplasts: sufficiently rapid deformations follow an elastic law since there is not enough time for substantial exchange of material, but over longer periods, a dynamic equilibrium is established between material in the plane of the membrane and that in the reservoir. Thus, in addition to the intensive elastic stretching, there is also the capacity for an extensive area change. An increase in tension shifts the equilibrium so as to increase the amount of material in the membrane; a decrease in tension shifts it in favor of the reservoir. The time for equilibration (if any) is unknown, but is longer than 5 min when  $\gamma = 4.00 \text{ mN m}^{-1}$  (Fig. 5).

We argue that the changes in area with time at constant tension represent changes in  $A_0$  as membrane material is transferred between the membrane and a reservoir. Thus, we divide the change in area into its elastic and extensive components by writing

$$\Delta A(\gamma, t) = \frac{\Delta \gamma}{k_A} \cdot A_0 + \delta A_0(\gamma, t) \quad (4)$$

In Figure 4, the first term on the right is represented by the sudden changes in  $\Delta A$  when the tension is changed, and the slower changes in  $\Delta A$  represent  $\Delta A_0$ . In Figure 6, these terms are specifically indicated. The results in Figure 5 also imply a change in  $A_0$ . Rewriting Equation 4 gives

$$\Delta \gamma = \left[ k_A \frac{\Delta A(\gamma, t)}{A_0} \right] - k_A \frac{\delta A_0(\gamma, t)}{A_0} \quad (5)$$

Because  $A$  is kept constant, the term in square brackets is very nearly constant and so the decrease in  $\gamma$  with time is a result of the increase in  $A_0$ . Taking time derivatives

$$\left( \frac{\partial \gamma}{\partial t} \right)_A = - \frac{k_A}{A} \cdot \left( \frac{\partial A_0}{\partial t} \right)_A \quad (6)$$

When  $\gamma = 2 \text{ mN m}^{-1}$ , the slope of the plot in Figure 5 is approximately  $3 \times 10^{-2} \text{ mN m}^{-1} \text{ s}^{-1}$ . Therefore, from Equation 6,

the fractional rate of increase in  $A_0$  at this tension is about  $1.2 \times 10^{-4} \text{ s}^{-1}$ , which is in the same range as the rates measured in response to step increases in tension (Fig. 4). If we assume that for very small changes in area in any cell  $\partial A_0/\partial t$  is only a function of tension, then because Figure 6 shows  $\partial A_0/\partial t$  to be strongly dependent on  $\gamma$ , Equation 6 implies that  $\partial A_0/\partial t$ , the rate of incorporation of reservoir material into the membrane, increases rapidly with increasing tensions. Extrapolating to higher tensions, the capacity of the membrane to expand rapidly as the tension approaches that necessary for lysis will increase the probability that a protoplast will survive rapid osmotic expansion.

The observation that the tension required to maintain a given area relaxes with time suggests that over a sufficiently long time this membrane obeys a surface energy law, *i.e.* surface tension constant for all deformations. Such a result is implied by the results of Kosuge and Tazawa (12) who measured the tension in the plasma membrane of protoplasts from *Boergeresia forbesii* to be approximately constant at about  $200 \mu\text{N m}^{-1}$  for deformations of different shapes. Indeed, our observation that protoplasts isolated in the same solution but equilibrated in hyper- or hypotonic solutions exhibited the same range of resting tensions also suggests that such a law may operate in the long term. Simple homogeneous contraction is inconsistent with the approximate constancy of  $\gamma$ , observed in osmotically contracted or expanded protoplasts and the irreversibility of the contraction indicated by the studies of Wiest and Steponkus (25). That a 15% alteration in area (which is small compared to changes experienced during a freeze-thaw cycle) does not measurably alter  $\gamma$  (measured at equilibrium) requires that a homogeneous contraction have an area elastic modulus ( $k_A$ ) of  $<1 \text{ mN m}^{-1}$ . In principle, a near-zero value of  $k_A$  is possible for small contractions in a pure one-component lipid membrane exactly at its critical temperature. However, even small amounts of slightly different lipid species or very small concentrations of protein remove the phase transition anomalies and produce  $k_A$  values 10 to 100 times larger than  $1 \text{ mN m}^{-1}$  (2, 14). The plasma membrane is composed of many different lipid and protein species and the phase transition of such a membrane is spread over several tens of degrees (17) and so only small contractions are possible at one temperature. Therefore, separate domains of 'frozen' lipids can contribute at most only part of the capacity to contract, and because of the nature of phase separations, this will be a reversible contraction. Therefore, on the basis of these and previous observations (28), we appeal to the existence of a reservoir of membrane area to absorb or provide membrane material during a contraction or expansion, respectively, to account for the extensive area change.

The existence of a reservoir in which molecules have a lower free energy than they would in a membrane at zero tension explains the ability of a membrane to reduce its area during osmotic contractions. Once volumetric contraction allows the membrane tension to relax to zero, molecules (or aggregates of molecules) move to the portion of the system with lower free energy. When a surface is in equilibrium with a reservoir and the molecular free energy difference is constant for all deformations, a surface energy law results, *i.e.*  $\gamma$  constant for all areas. As we discuss below, the surface forces operating in a membrane are large, of the order of  $100 \text{ mN m}^{-1}$  (10, 11, 27). The observations that  $\gamma$  is unchanged (in the range  $0.1 \pm 0.1 \text{ mN m}^{-1}$ ) over an area range of  $\pm 15\%$  indicates that a surface energy law is a good approximation to the SSR in the long term (many minutes).

The (resting) tension of a membrane in equilibrium with a reservoir is related to both the enthalpy and entropy of the process of transferring molecules from one to the other. Gruen and Wolfe (10) derive the tension in a one-component bilayer

$$\gamma_r = \frac{2}{a} \left[ (\mu_B^0 - \mu_k^0) - \frac{kT}{N} \ln \left( \frac{X_R}{N} \right) \right] \quad (7)$$

where the reservoir consists of aggregates of  $N$  molecules in concentration  $X_R$  whose standard chemical potential is  $\mu_R$ .  $\mu_B^0$  is the chemical potential of a molecule in the membrane when the tension is zero,  $T$  is the thermodynamic temperature,  $k$  is Boltzmann's constant, and  $a$  is the area of a molecule in the plane of the membrane. (Equation 2 of Ref. 10 has  $1/a$  instead of  $2/a$  since they define  $\gamma$  to be the tension of one monolayer of the bilayer.) The first term in Equation 7, the difference in chemical potential, represents a very complicated quantity; it will depend on the geometry of the reservoir aggregates and the environments of both, including ion concentrations and transmembrane electric fields. The second term is the contribution to the free energy of the communal entropy of membrane aggregates. This term indicates that, if all other variables are constant,  $\gamma_r$  will decrease for large reservoir concentration and increase if some change produces smaller aggregates. Values for this term are tabulated by Gruen and Wolfe (10); it is a small value for large  $N$ , but  $(\gamma_r a)$  is also a small energy. To illustrate this, consider the effect of changes in  $X_R$  on  $\gamma_r$ , with all other variables constant. If  $\Delta\gamma_r$  is the result of a change from  $X_R$  to  $X_R'$ , then Equation 7 gives

$$\frac{Na}{2kT} \cdot \Delta\gamma_r = \ln(X_R/X_R') \quad (7a)$$

If  $N$  were, for instance, 1000, a doubling of  $X_R$  would decrease  $\gamma_r$  by  $11 \mu\text{N m}^{-1}$ . If  $N$  were smaller, the effect would be proportionately larger. Given that very large expansion and contractions would be expected to dilute and concentrate (respectively) the reservoir, it would be of interest to see whether variation in  $\gamma_r$  appeared over a larger area change than that examined here.

As possible identities for the reservoir in this case, we have considered buckling or folding on a scale that is beyond the resolution of the light microscope (in which case the last term in Equation 7 is zero), or internal or external vesicles which are formed from or incorporated into the membrane. It seems unlikely that the very large, slow changes in membrane area could be predominantly intensive. We believe that an intensive contraction is responsible for the elastic changes in area, but it is difficult to imagine how such a contraction could be only slowly reversible. It is unlikely that the very large area changes sustained during osmotic manipulations are the result of similarly large changes in the membrane area density. Studies of protoplasts subjected to osmotic manipulations (22) indicate that large changes in area, up to 3-fold, are possible. The hydrocarbon tails of lipids have a very high volumetric modulus of elasticity (as does bulk liquid hydrocarbon) and so any intensive change in area in the bilayer regions of a membrane must involve a reciprocal change in the hydrocarbon thickness (11). It is difficult to imagine that a fluid mosaic membrane could sustain a 3-fold increase in area by undergoing a 3-fold area change in thickness.

This qualitative argument may be supported quantitatively, using crude arguments about bilayer mechanics. Following Israelachvili *et al.* (11), let us assume that the equilibrium area density of a bilayer is determined by a balance between an attractive term due to the interfacial energy  $\gamma_i$  of the hydrocarbon and aqueous phases and an electrostatic repulsion between headgroups, yielding the free energy per molecule ( $g$ )

$$g = \gamma_i a + c/a^n \quad (7b)$$

where  $a$  is the area per molecule and  $c$  and  $n$  are parameters of the repulsion model. This yields a bilayer elastic modulus

$$k_A = 2(n+1)\gamma_i \quad (7c)$$

Taking  $n = 1$  (that is, treating the headgroups as a two-dimensional van der Waals gas, but remarking that any model must have  $n \approx 1$  at the equilibrium area density) and putting  $\gamma_i$  equal to the alkane/water interfacial energy of  $50 \text{ mJ m}^{-2}$  yields  $k_A = 200 \text{ mN}$

$\text{m}^{-1}$ , a value similar to that obtained in this study for the whole membrane (bilayer plus proteins). Thus, a 3-fold, intensive stretching would be expected to produce tensions of several hundred  $\text{mN m}^{-1}$  (and several times  $kT$  in energy per molecule). In this study, membranes were found to lyse at about  $5 \text{ mN m}^{-1}$ .

Submicroscopic folds, vesicles, and lipid bodies have been observed adjacent to the plasma membrane in ultrastructural studies of some tissues (1). (Such folds would have to be stabilized by membrane-membrane attraction in order to sustain a finite tension.) Pleating or folding of the plasma membrane, however, is not observed in electron micrographs of osmotically contracted protoplasts (8). We suggest that vesicles are likely candidates for the reservoir: though the external loss of vesicles large enough to be visible under the light microscope is only rarely observed during re-expansion of contracted protoplasts, submicroscopic vesicles, either internal or external, are more commonly present in electron micrographs. We note that the endocytosis of a vesicle of radius  $r_v$  from a protoplast of radius  $R$  changes the area by a fraction  $(r_v/R)^2$  and the volume by  $(r_v/R)^3$  so that a substantial change in protoplast area could be thus achieved with negligible change in volume, and so this model for contraction is not in conflict with the observation that protoplasts behave as ideal osmometers (25).

A reaction in which vesicles are continually exchanged with the plasma membrane will have kinetics which are strongly dependent on the tension in the membrane since a change in tension of  $1 \text{ mN m}^{-1}$  changes the free energy per lipid molecule by 0.06 times the thermal energy ( $kT$ ) (27). For a vesicle of some thousands of molecules, this would imply a large change in the reaction free energy (10). Figure 6 implies that in this system the incorporation rate is strongly dependent on  $\gamma$ .

Our value of  $230 \text{ mN m}^{-1}$  for the area elastic modulus of the plasma membrane of protoplasts is smaller than that of the RBC, measured as  $450 \text{ mN m}^{-1}$  by Evans and Waugh (7). This is not surprising: the RBC has a reinforcing network of spectrin, whereas the protoplast plasma membrane is here deprived of its usual reinforcement, the cell wall.

Wobschall (26) has measured the elastic moduli of lipid bilayers to be  $150$  to  $300 \text{ mN m}^{-1}$ . Theoretical calculations of  $k_A$  for pure lipid bilayers yield values in this range: from a molecular theory, Marčelja (13) calculates that the contribution to  $k_A$  from the lipid tails is  $150$  to  $200 \text{ mN m}^{-1}$ , and using a bulk surface tension argument Israelachvili *et al.* (11) calculate  $k_A = 200 \text{ mN m}^{-1}$ .

The value of  $k_A$  for a real membrane is expected to depend on its composition.  $k_A$  will be much lower if different lipid phases coexist and will depend on the shape of the  $\gamma$ - $T$  composition phase diagram (14). The effect of the presence of proteins will depend on their concentration, the extent to which the protein molecules themselves are laterally compressible, and the extent to which they change the compressibility of the neighboring lipids. This last effect is expected to be considerable if the lipids are in or near their phase coexistence range of temperatures and tensions (2, 27). The experiments reported here were carried out at room temperature and so it is reasonable to suppose that in neither case was there a substantial amount of solid lipid phase in the membrane (17). Though preliminary experiments showed no significant differences between  $k_A$  of acclimated and nonacclimated protoplasts, it would be interesting to conduct similar experiments at lower temperatures to discover whether the elastic modulus of the membranes from nonacclimated plants decreases as higher melting point lipids become capable of phase transitions in response to changes in tension. This would be of particular interest since some researchers have reported an increase in the concentration of lipids with shorter or less saturated hydrocarbon chains in the membranes of plants during cold acclimation (20).

Finally, the foregoing analysis of the SSR has led us to propose a description of the molecular events which lead to lysis of



membranes of nonacclimated protoplasts during an osmotically induced cycle of sufficiently large contraction and expansion, such as during a freeze-thaw cycle. Upon exposure to hypertonic solutions, the volume of a protoplast contracts and the tension in the surrounding membrane is quickly relaxed to zero. A fractional volume change of  $3 \times 10^{-4}$  suffices, and this occurs within milliseconds. Since at zero tension the membrane may contract without doing work (and since the reservoir of a membrane with a finite tension has a lower free energy per molecule [10]), the reservoir-membrane equilibrium is altered slightly and material is subducted into the reservoir, on a time scale of several minutes, until the protoplast regains sphericity and a small resting tension. When the protoplast is returned to isotonic conditions, water begins to enter rapidly. This stretches the membrane elastically and creates a large (several  $\text{mN m}^{-1}$ ) tension. This induces a re-incorporation of reservoir material. The area expansion rate is determined by the osmotic conditions, the cell size, and the hydraulic conductivity of the membrane. If reservoir incorporation can reach a rate which equals the required area expansion at tensions low enough to avoid lysis and if this rate may be maintained throughout the expansion, then the protoplast survives the expansion as observed in acclimated protoplasts (21). That is, survival of a given contraction-expansion cycle depends on the extent of readily available material in the reservoir, and the rate at which it may be re-incorporated.

Thus, in Figure 7, protoplasts whose membranes were maintained under tension during volumetric contraction (surface area conserved) transferred little or no membrane material from the plasma membrane to the reservoir. In contrast, a considerable transfer occurred in the unconstrained protoplasts. When the protoplasts which remained under tension were returned to isotonic conditions, their plasma membranes still had sufficiently large area to surround the equilibrium isotonic volume. In contrast, when the unconstrained protoplasts were returned, the rate of re-incorporation of membrane material was slow compared to the influx of water, and so the intensive stretching component of the area enlargement increased till the tension was sufficient to lyse it.

*Acknowledgment*—We thank Michael F. Dowgert for the photomicrographs and his involvement in the latter stages of this project and its continuation.

#### LITERATURE CITED

- BAIRD LAM, AC LEOPOLD, WJ BRAMLAGE, BD WEBSTER 1979 Ultrastructural modifications associated with imbibition of the soybean radicle. *Bot Gaz* 140: 371-377
- BATES EH, J WOLFE 1981 The elasticity of protein-lipid bilayer membranes and its physiological significance. In L Bata ed, *Liquid Crystals: Research and Applications*. Akademiai Kiado, Budapest. In press
- CHIEN S, KP SUNG, R SKALAK, S USAMI, A TOZEREN 1978 Theoretical and experimental studies on viscoelastic properties of erythrocyte membrane. *Biophys J* 24: 463-487
- COLE KS 1932 Surface forces of the *Arbacia* egg. *J Cell Comp Physiol* 4: 421-433
- DUELING HJ, W HELFRICH 1976 Red blood cell shapes as explained on the basis of curvature elasticity. *Biophys J* 16: 861-868
- EVANS EA, R SKALAK 1979 *Mechanics and Thermodynamics of Biomembranes*. CRC Press, Boca Raton, FL
- EVANS EA, R WAUGH 1977 Osmotic correction to elastic area compressibility measurements on red cell membrane. *Biophys J* 20: 307-313
- GORDON-KAMM WJ, PL STEPONKUS 1981 Surface areal changes in isolated protoplasts: electron microscopic observations. *Plant Physiol* 67: S-122
- GOMPERTS B 1977 *The Plasma Membrane: Models for Structure and Function*. Academic Press, New York
- GRUEN DWR, J WOLFE 1982 Lateral pressures and tensions in lipid monolayers and membranes. *Biochim Biophys Acta* 688: 572-580
- ISRAELACHVILI JN, DJ MITCHELL, BW NINHAM 1976 Theory of the self-assembly of hydrocarbon amphiphiles into micelles and vesicles. *J Chem Soc Faraday Trans II* 72: 1525-1568
- KOSUGE Y, M TAZAWA 1979 Increase in tension at the surface of protoplast as a sign of cell wall formation in *Boergeresia forbesii*. *Bot Mag Tokyo* 92: 315-323
- MARČELJA S 1974 Chain ordering in liquid crystals. II. Structure of bilayer membranes. *Biochim Biophys Acta* 367: 165-176
- MARČELJA S, J WOLFE 1979 Properties of bilayer membranes in the phase transition on phase separation region. *Biochim Biophys Acta* 557: 24-31
- MITCHISON JM, MM SWANN 1954 The mechanical properties of the cell surface. *J Exp Biol* 31: 443-472
- NORRIS CH 1939 The tension at the surface and other physical properties of the nucleated erythrocyte. *J Cell Comp Physiol* 14: 117-133
- QUINN PJ, WF WILLIAMS 1978 Plant lipids and their role in membrane function. *Prog Biophys Mol Biol* 34: 109-173
- RAND RP 1964 Mechanical properties of the red cell membrane. II. Viscoelastic breakdown of the membrane. *Biophys J* 4: 303-316
- RAND RP, AC BURTON 1964 Mechanical properties of the red blood cell membrane. I. Membrane stiffness and intracellular pressure. *Biophys J* 14: 115-135
- STEPONKUS PL 1978 Cold hardiness and freezing injury of agronomic crops. *Adv Agron* 30: 51-98
- STEPONKUS PL, MF DOWGERT 1980 Effect of cold acclimation on the plasma membrane expansion potential of isolated protoplasts. *Plant Physiol* 63: S-238
- STEPONKUS PL, SC WIEST 1978 Plasma membrane alterations following cold acclimation and freezing. In PH Li and A Sakai, eds, *Plant Cold Hardiness and Freezing Stress—Mechanisms and Crop Implications*. Academic Press, New York, pp 75-91
- STEPONKUS PL, SC WIEST 1979 Freeze-thaw induced lesions in the plasma membrane. In JM Lyons, DG Graham, and JR Raison, eds, *Low Temperature Stress in Crop Plants: The Role of the Membrane*. Academic Press, New York, pp 231-254
- WAUGH R, EA EVANS 1979 Thermoelasticity of red blood cell membranes. *Biophys J* 26: 115-132
- WIEST SC, PL STEPONKUS 1978 Freeze-thaw injury to isolated spinach protoplasts and its simulation at above-freezing temperatures. *Plant Physiol* 62: 699-705
- WOBSCHELL D 1971 Elasticity of lipid bilayers. *J Coll Int Sci* 36: 385-390
- WOLFE J 1979 Membrane biophysics: the temperature dependence of some physiological processes. Ph.D. thesis, the Australian National University, Canberra
- WOLFE J, PL STEPONKUS 1981 The stress-strain relation of the plasma membrane of isolated plant protoplasts. *Biochim Biophys Acta* 643: 663-668

#### APPENDIX 1: MEASUREMENT OF SURFACE TENSION

A spherical membrane of radius  $R$  withstanding a hydrostatic pressure difference  $P_i$  must have a bifacial tension  $\gamma = P_i R/2$ . If the pressure in the cytoplasm is  $P_c$  and that in the pipette  $P$ , and if the tension  $\gamma$  is equal in both the delimited region and that outside the pipette, then  $\gamma = P_i R/2 = (P_i - P_c)R/2$ , whence Equation 1. Equation 1 may be used directly to measure  $\gamma$  in a protoplast which has been deformed in the pipette. Determination of the resting tension  $\gamma_r$  is less direct.

Inasmuch as it is necessary to deform the protoplast in order to measure its tension, it is strictly impossible to measure the resting tension  $\gamma_r$  of an undeformed protoplast. However, it may be estimated by extrapolation to  $\Delta A = 0$  of a plot of  $(\Delta A, \gamma)$  for small deformations. Using small pipettes ( $a = 2 \mu\text{m}$ ) to impose small deformations ( $D < a$ ), the change in area is less than 0.2%, and  $\gamma_r$  may be equivalently estimated as the slope of a line through  $(0, 2/R)$  which is fitted to the initial portion of a plot of  $P$  versus curvature of the membrane in the pipette.

This use of the elastimeter to calculate membrane tension requires the assumptions that the hydrostatic pressure immediately inside the plasma membrane is everywhere the same and that the tension in the plasma membrane is the same in the sections inside and outside the pipette. In all experiments where tension was measured, the protoplast was positioned so that the vacuole did not intrude into the pipette, thereby avoiding the possibility of a portion of the cytoplasm being sealed between the tonoplast and plasmalemma and experiencing a different hydrostatic pressure from the rest of the cytoplasm.

The assumption of uniform tension in the membrane requires that the friction at the pipette lip is negligible. In all observations, the membrane appeared to slide freely over the lip and to move in the pipette without backlash. When cells were drawn completely into the pipette forming rods  $\approx 100 \mu\text{m}$  long which pressed against the glass for nearly all their length, pressures of only a few tens of Pa were necessary to move them in either direction. We also demonstrated that frictional forces were small, using a pipette with a small indentation in the pipette lip. Protoplasts did not seal on such a pipette, and when large negative pressures were applied, the flow through the indentation caused the protoplast to rotate

on the pipette lip (at several revolutions/s), suggesting that friction between membrane and glass was small.

## APPENDIX 2: MEASUREMENT OF CHANGE IN AREA

Consider the spherical segment outside the pipette (Figs. 1 and 2). From simple geometry, its volume  $V_s$  and area  $A_s$  are

$$A_s = 2\pi R^2 \left[ 1 + \left\{ 1 - \left( \frac{a}{R} \right)^2 \right\}^{1/2} \right] \quad (A1)$$

$$V_s = \frac{\pi}{3} \left[ 2 + \left\{ 2 + \left( \frac{a}{R} \right)^2 \right\} \left\{ 1 - \left( \frac{a}{R} \right)^2 \right\}^{1/2} \right]$$

using binomial expansions gives, for  $a < R$

$$A_s = 4\pi \left[ R^2 - \frac{a^2}{4} - \frac{a^4}{16R^2} \dots \right]$$

$$\frac{dA_s}{dR} \approx 8\pi R$$

$$V_s = \frac{4\pi}{3} \left[ R^3 - \frac{a^2}{8} R + O\left(\frac{a^6}{R^3}\right) \right]$$

$$\frac{dV_s}{dR} = \frac{4\pi}{3} \left[ 3R^2 - \frac{a^2}{8} + O\left(\frac{a^6}{R^4}\right) \right]$$

$$\therefore \frac{dV_s}{dA_s} = \frac{R}{2} \left[ 1 - \frac{1}{24} \left( \frac{a}{R} \right)^2 \right] + \text{smaller terms}$$

Now  $(a/R)$  is usually  $1/4$ , so to an accuracy of 0.3%

$$\frac{dV_s}{dA_s} = \frac{R}{2} \quad (A1b)$$

When a protoplast is deformed at constant volume

$$\Delta V = \delta V_p + \delta V_s = 0 \quad (A1c)$$

where the subscripts  $p$  and  $s$  refer to the portion in the pipette and the large spherical portion. Also

$$\Delta A = \delta A_p + \delta A_s = \delta A_p + \delta V_s \frac{dA_s}{dV_s} = \delta A_p - \delta V_p \left( \frac{dA_s}{dV_s} \right) \quad (A2)$$

In practice,  $\delta A_p$  is rather larger than  $2/R(\delta V_p)$  so that the approximation that  $dV_s/dA_s = R/2$  is not critical.

The radius  $r$  of the spherical portion inside the pipette is given

by

$$r = \begin{cases} (D^2 + a^2)/2D & D \leq a \\ a & D > a \end{cases} \quad (A3)$$

From Equations A1 and A3 and formulae for the area and volume of a cylinder of length  $(D - a)$

$$\delta A_p = \begin{cases} \pi(a^2 + D^2) & D \leq a \\ 2\pi a D & D > a \end{cases} \quad \delta V_p = \begin{cases} \pi D(D^2 + 3a^2) & D \leq a \\ \pi a^2(D - \frac{a}{3}) & D > a \end{cases} \quad (A4)$$

Now before the cell is deformed, the initial value of  $D$ ,  $D_0 = a^2/2R$ , and therefore

$$\delta A_p = \begin{cases} \pi(D^2 - D_0^2) & D \leq a \\ \pi(2aD - D_0^2 - a^2) & D > a \end{cases}$$

$$\delta V_p = \begin{cases} \frac{\pi}{6}(D - D_0)(D^2 + DD_0^2 + D_0^2 + 3a^2) & D \leq a \\ \frac{\pi}{6}(6Da^2 - 2a^3 - D_0(D_0^2 + 3a^2)) & D > a \end{cases} \quad (A5)$$

and substituting Equation A5 in A2 gives Equation 2.

The absolute error in  $\Delta A$  is larger for larger protoplasts. Consider a protoplast with radius  $20 \mu\text{m}$  (among the largest encountered in the population) and a pipette of typical radius of  $5 \mu\text{m}$ . A change in membrane tension of  $2 \text{ mN m}^{-1}$  changes the hydrostatic pressure in the protoplast by  $200 \text{ Pa}$  and thus alters its volume by a factor of  $2 \times 10^{-4}$ , or  $6 \mu\text{m}^3$ . This effect causes an error in Equation 2 equivalent to an error of  $\sim 200 \text{ nm}$  in the measurement of  $D$ . Since this is a smaller distance than can be resolved optically, it is neglected.

The accuracy of Equation 3 (which is equivalent to the validity of the assumption that  $V$  is constant) may be assessed directly in an experiment using a relatively large pipette to produce large area deformations, and measuring  $d$  and  $D$  (Fig. 2) for different deformations. Again from geometry,  $R = (d^2 + a^2)/2d$  and substituting in Equation A1 gives, for all  $d$

$$A_s = \pi(a^2 + d^2) \quad V_s = \frac{\pi d}{6}(d^2 + 3a^2) \quad (A6)$$

and Equations A4 and A6 give

$$A = \begin{cases} \pi(D^2 + 2a^2 + d^2) & D \leq a \\ \pi(2Da + a^2 + d^2) & D > a \end{cases}$$

$$V = \begin{cases} \frac{\pi}{6}[d(d^2 + 3a^2) + D(D^2 + 3a^2)] & D \leq a \\ \frac{\pi}{6}[d(d^2 + 3a^2) + 2a^2(3D - a)] & D > a \end{cases} \quad (A7)$$